





In its very name the Mannequal™ denotes equality, in its design it reflects acceptance and in its inclusion it expresses unity.



# *the mannequal*



## an inspired idea: the beginnings

The Mannequal™ has been created to bridge one of the many gaps found in our society; the void that exists between disabled customers and the exclusive fashion world.

It was designed by Sophie Morgan who was irritated by the lack of representation of disability on the high street and decided to create a product that would call an end to disability discrimination. The Mannequal™ evolved and is the first display product of its kind - a wheelchair for a mannequin.

In the UK there are 1.94 million people, aged between 16 and 30 who have a disability and 600 million worldwide. The symbol that has come to reflect this category of person, regardless of age, colour or nationality, is the universally recognised wheelchair. While the Mannequal™ is essentially a display chair, the message of inclusivity that this will give to all customers cannot be underestimated.

Prior to its launch, the Mannequal™ is already being used by Canadian fashion designer Izzy Camilleri, who has launched the first adaptive clothing range specifically designed for seated clientele.



# *product specification*



## *a blank canvas for creativity*

The Mannequal™ has been designed to seat both male and female mannequins of standard height and width measurements and it can be decorated and styled to coordinate aesthetically, unobtrusively and subtly with any in store display or shop window.

It is specifically designed to seat a mannequin without obstructing the view of the clothing. The mannequin can be styled in the same manner that would be used to style any other seated mannequin.

The Mannequal™ can be delivered in white; a blank canvas for the creative team to manipulate according to their intended brief, or in a range of colours including pantones. It can also be personalised, to show a brand or company logo or design.

“Mannequal™ addresses the need for visually arresting design in an area where functionality has repeatedly failed to embrace aesthetics. Sophie Morgan is a creative talent with a healthily political edge...watch this space. ”

- Wayne Hemingway M.B.E, Fashion Designer

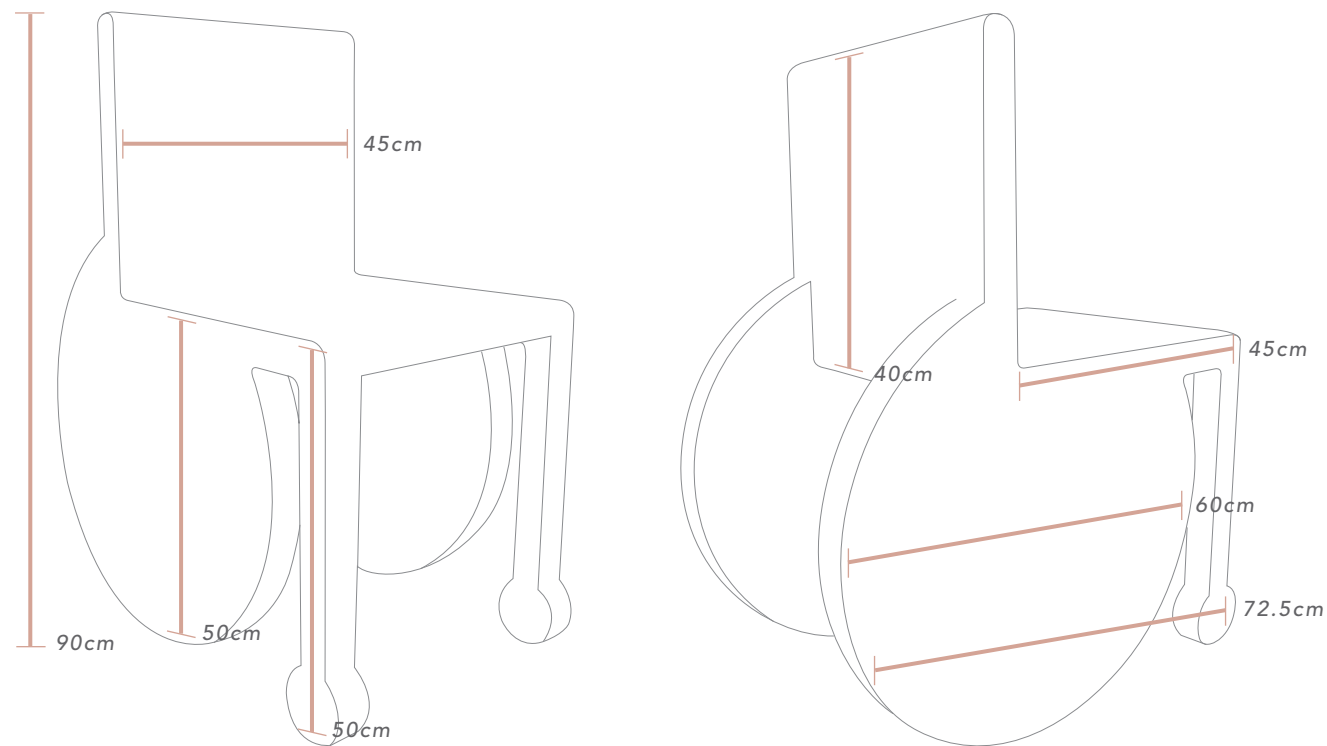

---

HEIGHT: 90 cm

---

WIDTH: 45 cm

---

WEIGHT: Approx. 20 kg

---

COLOUR:

(No minimum order) -

- Black
- White
- Red
- Blue
- Grey
- Green

(Minimum order of 5) -

- Any pantone colour
- 

FINISH: matte or gloss

---

MATERIAL: fiber glass

---

# *the way forward*

The topic of inclusivity within the fashion world has been increasing momentum and the benefits of a product such as the Mannequal™ cannot be ignored. Not only does it offer equality to all customers, but the Mannequal™ is a valuable asset to the retailer.

## benefits for the retailer

- › The Mannequal™ exists as a reflection of a commitment to ensure that responsibilities have been met under the Disability Discrimination Act, and that goods and services are accessible.
- › The Mannequal™ clearly suggests an attitude of acceptance, and therefore reinforces the shops offer of assistance and guidance for any customer, disabled or not.

## benefits for the customer

- › Not only is the Mannequal™ a reflection of correct moral and ethical conduct, more importantly it is also helps to include and empower disabled shoppers.
- › The Mannequal™ can act as an in-store guide to fashion that is suited to a seated customer. It also communicates with the able-bodied shopper who can refer to the seated mannequin for inspiration.



February 2010 Debenhams became first UK high street retailer to use a disabled model.



In July 2008, BBC Three premiered Britain's Missing Top Model, following eight young women with disabilities competing for a modelling contract.

# about the designer



“ My accident taught me that there is only positivity to be found in change. It’s a privilege to see the world from this new perspective. ”

Sophie Morgan, now 25, broke her back in a car accident in 2003 and is paralysed from the chest down and in a wheel chair for life. Seeing the world from a different perspective has led her to become an opinion former who is changing perceptions of disability by inspiring confidence in disabled people and acceptance and equality in society.

No stranger to the modelling and fashion world , Sophie aims to see retailers supporting disability. The manifestation of this is a ‘wheelchair’ for mannequins, for use in shop windows and in-store displays which she pioneered and designed.

Sophie, recently nominated for ‘Young Disabled Person of the Year Award’, has featured on several BBC shows, one of which ‘Britain’s Missing Top Model’ focused on the fashion industry and its relationship with disabled models.

An artist trained at Goldsmiths University, Sophie also works as a TV presenter (The One Show, CBBC and BBC3) as well as director of the IMPERFECT campaign, which supports victims of disability discrimination and empowers young disabled people. She lives and works in London.

“ Disabled people have the right to be represented in every walk of life, fashion included. The Mannequal™ offers an attractive and chic way of doing this, helping people in wheelchairs to shop, while opening the minds of others around them. The chairs are beautifully designed, and would look great in any clothing store. I look forward to seeing them up and down Bond Street in their various colours and styles! „

- Jacquetta Wheeler, Model & Vogue Columnist





**CLEO B**

RICHARD TOUNG TURKEY PHOTOGRAPHY

# *prices & ordering*

## *price & delivery information:*

---

- Costs Per Mannequial: £295 | €365 | US \$450 | CAD \$475  
(currencies subject to change)
- Lead time 8-10 weeks, for faster delivery airfreight is available
- Aftercare and repairs not included in cost

## *to place an order, please contact:*

---

LONDON, UK

Universal Display Fittings Co. Ltd  
Unit 130-132 Network Hub  
300 Kensal Road  
London W10 5BE

T: 0208 206 5010

F: 0208 969 4215

info@universaldisplay.co.uk

NEW YORK, USA

Universal Display & Design Inc.  
2nd Floor  
138 West 25th Street  
New York, NY 10001 USA

T: 212 242 0374

F: 212 989 0706

info@universaldisplayusa.com

## *for more details contact sophie morgan:*

---

T: 0208 240 7114 | M: 0776 601 5506 | [sophie@mannequial.com](mailto:sophie@mannequial.com)

“Sophie Morgan’s Mannequal™ is the first product to exist which permits retailers to express an inclusive attitude to people who use wheelchairs. It also shows that people with disabilities not only want to be recognised within society, but that they are equally as interested in fashion and trends as everyone else.”

- Izzy Camilleri, Fashion Designer

[www.mannequal.com](http://www.mannequal.com)



PATENT PENDING IN (USA) AND REG. DES. 4013261 (IN UK)